



GM 4L80E Intermediate Clutch PowerPack® Stock, Heavy Duty, Hi-Performance, Race Vehicles

ALTO PART # 031757A & 031757AHP

Alto # 031757A POWERPACK® CONTENTS:

- (5) 031714-152 (.060" / 1.52mm) Friction Plates
- (5) 31705-160 (.063" / 1.60mm) Steel Plates
- (1) 028252-106 (.106" / 2.69mm) Heavy Duty Snap Ring

Alto # 031757AHP POWERPACK® CONTENTS:

(Hi-Performance, Racing & Heavy Duty Applications)

- (5) 31742A (.060" / 1.52) Red Eagle® Friction Plates
- (5) 031705HK160 (.063" / 1.60mm) Kolene® Turbulator® Steel Plates
- (1) 028252-106 (.106" / 2.69mm) Heavy Duty Snap Ring

INSTALLATION INSTRUCTIONS

Stack-up is the same method as OE, starting with a steel plate and alternating friction and steel plates. End with the top pressure plate. Install the heavy-duty snap ring leaving the opening at the 9 o'clock position.

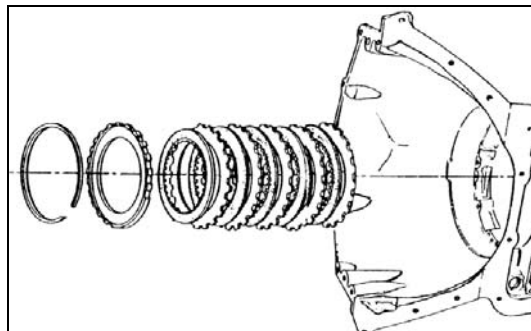

Apply air (40 PSI max) to center support port for the intermediate several times to seat the clutch pack elements. Clutch pack clearance is .040" to .107" (1.02 to 2.72mm) check with feeler gauge between the bottom of the snap ring and the top of the pressure plate.

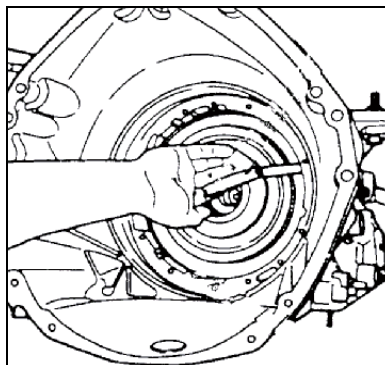

The 031757AHP would be the best choice for Hi-Performance or rough service operation.