



GM Direct Clutch PowerPack® TH200/TH200C/TH2004R

ALTO PART # 043757

Alto # 043757POWERPACK® CONTENTS:

- (8) 043740A Red Eagle® Frictions (.061" / 1.55mm)
- (7) 043701AK Kolene® Steel Plates (.060" / 1.52mm)
- (1) 043701K Kolene® Steel Plate (.078" / 1.98mm)
- (1) 043760A432 Top Pressure Plate (.170" / 4.32mm)

INSTALLATION INSTRUCTIONS

TH 200/C Stack-up is the same as OE, starting with a .060" steel plate and then alternately installing friction and steel plates ending with the pressure plate. Install the top pressure plate with the micro-finish facing the top friction plate. (Do not use the .078" Kolene® steel plate in this stack-up).

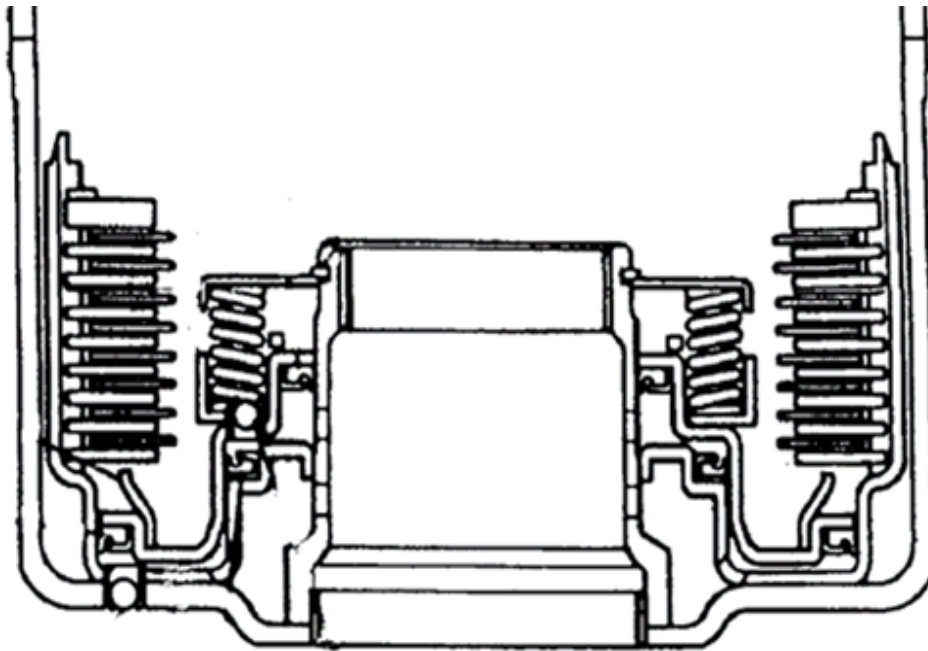

TH 200-4R Stack-up is the same as OE, starting with the .078" Kolene® Steel Plate and the alternately install friction and steel plates ending with the pressure plate. Install the top pressure plate with the micro-finish facing the top friction plate. Clutch pack clearance should be .008" to .010" per lined plate. Check clearance using a feeler gauge between the snap ring and the top pressure plate.