



Ford C6/E4OD/4R100 Forward Clutch PowerPack® 66-On Hi-Performance, Racing, Drag Boats, Street Rods

ALTO PART # 026755

Alto # 026755 POWERPACK® CONTENTS:

(Hi-Performance Applications)

(6) 026740 Red Eagle® Friction Plates

(6) 026701AK Kolene® Steel Plates

(1) 026760-630 Top Pressure Plate

(1) 026760A673 Bottom Pressure Plate

INSTALLATION INSTRUCTIONS

Stack up is the same method as OE. Start with the bottom apply plate dished side down. Install the cushion spring then alternately install the friction and steel plates starting with a steel and ending with a friction plate. Install the top pressure plate and the selective snap ring.

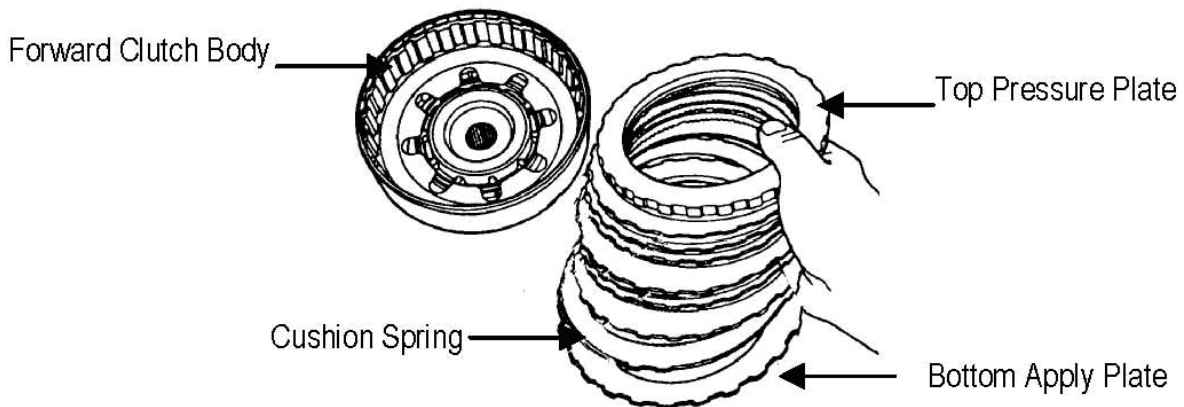

Note: Always pre-soak friction elements for at least 15-20 minutes in manufacturer recommended ATF.

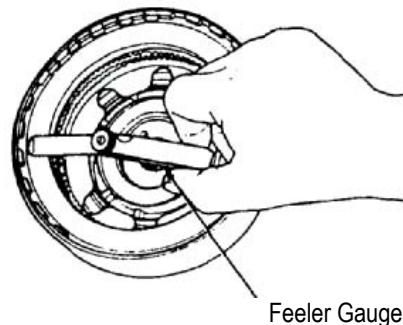

Apply air to assembled clutch pack several times to seat the friction and steel elements. Use a feeler gauge to measure between the bottom of the selective snap ring and the top of the pressure plate. Clearance should be .040" to .075" (1.02 to 1.91mm). To achieve the recommended clearance, use one of the selective snap rings available from Alto Products Corp.

The following Selective Snap Rings are available from Alto: 026251-050; 026251-058; 026251-062; 026251-076; 026251-090; 026251-094; 026251-112; 026251-130. Please contact your sales representative for more information.

Shift . . . Your Thinking