



ALTO PRODUCTS CORP.

091901

New Product Release

Direct Clutch PowerPack - TH200 – TH200C – TH2004R
Alto Kit # 043757

CONTENTS OF THIS KIT INCLUDE:

7 043740A	Red Eagle Frictions (.061" / 1.55mm)
7 043701AK	Kolene Steel Plates (.060" / 1.52mm)
1 043760A432	Top Pressure Plate (.170" / 4.32mm)

Problem: The direct clutch has sufficient capacity for the normal consumer vehicle. However, if higher horsepower and more torque demands are introduced, the direct clutch will fail.

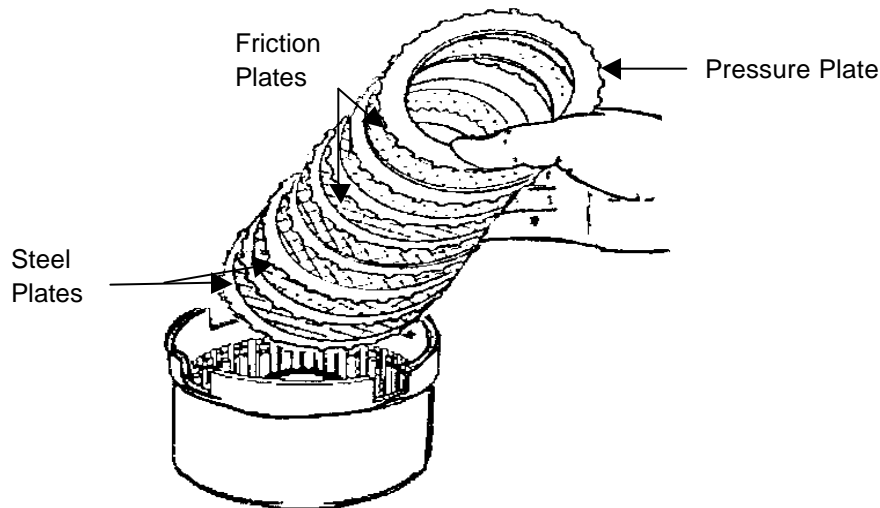

Solution: Alto Products Corp. has designed a new Powerpack for the direct clutch. You can replace the normal 5 friction and 5 steel plate setup with 7 friction and 7 steel plates. This added capacity will allow for the addition of higher engine horsepower, and will also handle the additional torque demands.

Installation: Stack up is the same as OE, starting with a steel plate and then alternately installing friction and steel plates ending with the pressure plate. Clutch pack clearance should .008" to .010" per lined plate. Check clearance using a feeler gauge between the snap ring and the bottom of the top pressure plate.

Shift... Your Thinking

Alto Way · Atmore · AL · 36504
251.368.7777 · Fax: 251.368.7774

www.altoUSA.com · Email: sales@altoUSA.com