



ALTO PRODUCTS CORP.

071901

New Product Release

PowerBand GM 200 / 2004R

ALTO PART # 043961 (Red Eagle) # 043961K (Kevlar)

Transmission	Buick – Century / Electra / Estate Wagon / Lesabre / Regal / Riviera / Skyhawk
THM 200	Cadillac – Fleetwood
	Chevrolet – Camaro / Caprice / Chevette / El Camino / Luv Pickup / Malibu / Monte Carlo / Monza / Nova / S10 Pickup
THM 200C	GMC – Caballero
	Oldsmobile – Delta 88
THM 2004R	Opel – Deluxe / Sport
	Pontiac – Bonneville / Catalina / Firebird / Grand Prix / Lemans / Parisienne / Phoenix / Ventura

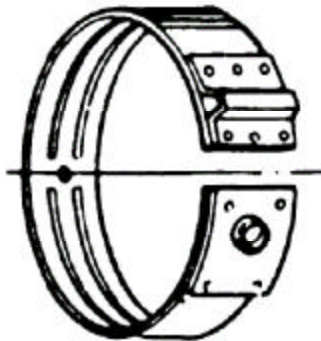

OE Style Band

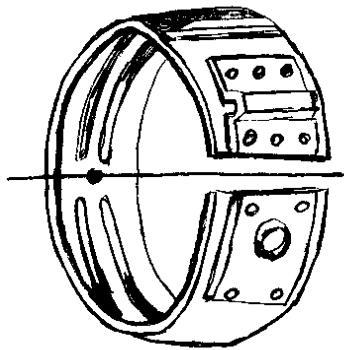

Alto PowerBand 18% wider

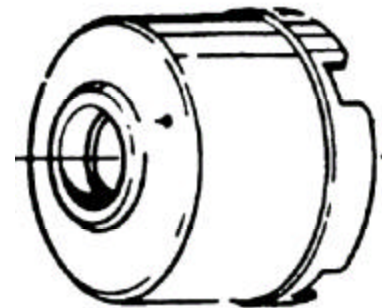

Drum must be smooth and flat

DURABILITY AND PERFORMANCE BENEFITS: Provides 18% more friction surface for torque load enhancement, and the ability to provide a more positive 2nd gear shift or 2-4 shift. All bands have high carbon heat-treated “thick” anchors to prevent tearing. These bands are available in the race proven RED EAGLE lining or the KEVLAR lining. This is a welcome addition for the lightest 3 - 4 speed OEM - GM automatic transmission.

Installation: Same installation procedures as the OE style band. Use the band apply pin-checking tool, and inch pound torque wrench to determine the correct length servo pin. The drum surface area must be smooth and flat where the band lining will make contact.

Shift... Your Thinking

Alto Way · Atmore · AL · 36504
251.368.7777 · Fax: 251.368.7774

www.altoUSA.com · Email: sales@altoUSA.com