

AltoUpdate...

MAKE	TRANSMISSION	APPLICATION	YEAR
General Motors	700R4, 4L60, 4L60E	Rear Wheel Drive GM	89-On

DESCRIPTION & NOTES...

Matches the "apply feel" of the Belleville spring...

Reuse Your Existing Drum with Our #057758 Wave Spring and Spacer Plate Kit...

The Problem:

The Belleville spring located in the bottom of the reverse input drum flexes and displaces large amounts of metal. The metal is moved throughout the transmission accelerating the wear of bushings, bearings, planetary pinions, and the valve body. The Belleville spring may also catch in the groove and cause a delayed reverse engagement.

Kit #057758 Contents

- (1) 057703A089Wave Spring
- (1) 057703-230Spacer Plate

The Solution:

Alto Products Corp. DrumSaver™ wave spring and spacer plate kit is designed to match the "apply feel" of the Belleville spring, while in most cases, allowing the reuse of the existing drum.

Use the easy installation instructions provided in the 057758 kit for the best results.

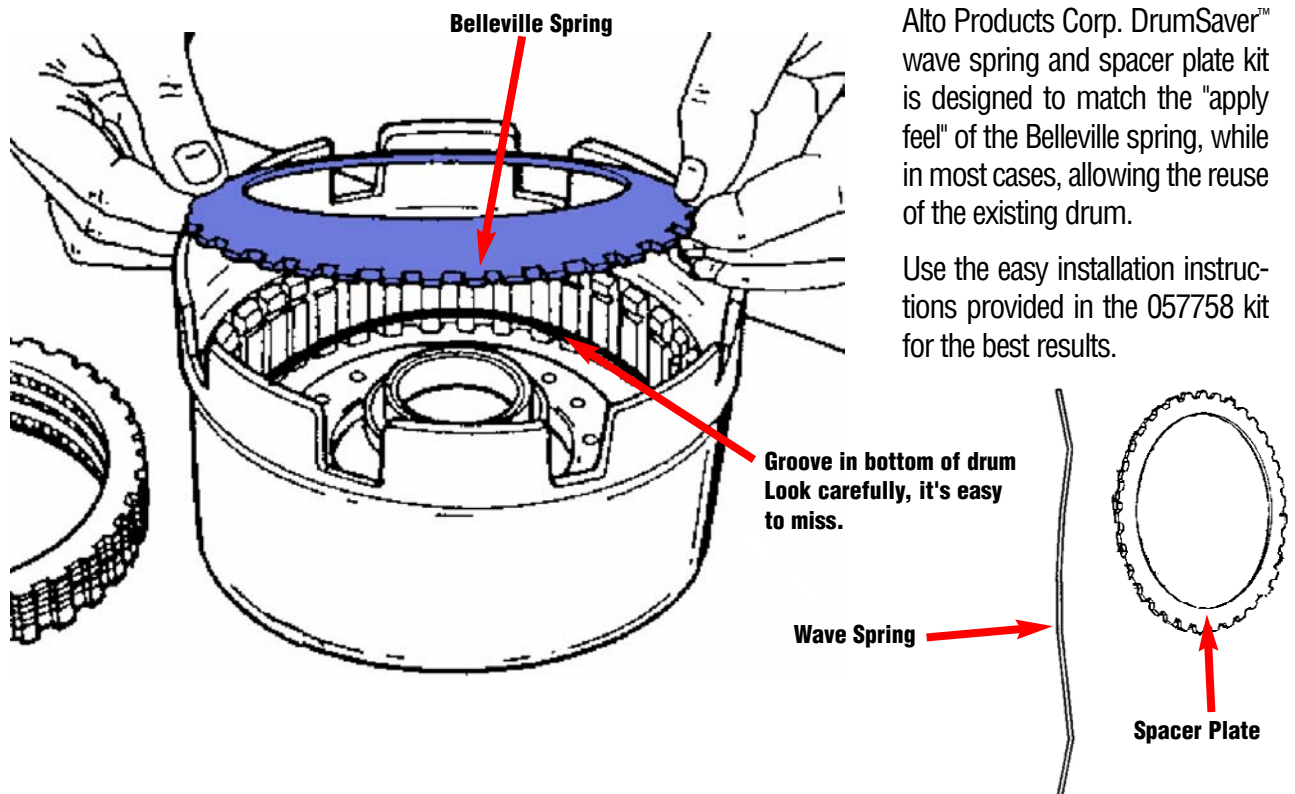

Alto Way • PO Box 1088 • Atmore • AL • 36504
Tel: 251.368.7777 • Fax: 251.368.7774 • www.altoUSA.com

Clutches and Gears for Automatic and Standard Transmissions

0305009

