



GM 4T60 & 4T60-E
Fourth Clutch Repair Kit PowerPack®
Featuring the Patented "BENT TOOTH" Design

ALTO PART #062758; 062758A & 062758B

Alto # 062758; 062758A & 062758B POWERPACK® CONTENTS:

****NOTE:** There are three (3) different kits for the 4T60 & 4T60E Transaxles depending on the model year.
The correct kit must be used.

062758

For ALL Single Plate Applications (For Patent #0496789)

- (1) 062736 (.090" / 2.29mm) Bent Tooth Friction Plate
- (2) 062707A (.076" / 1.93mm) Special Undercut ID Steel Plates

062758A

For Dual Plate Applications (1991-1992)

- (2) 062736A (.070" / 1.78mm) Bent Tooth Friction Plates
- (2) 062717A (.074" / 1.88mm) Special Undercut ID Steel Plates

062758B

For Dual Plate Applications (1993 - UP)

- (2) 062736A (.070" / 1.78mm) Bent Tooth Friction Plates
- (2) 062727A (.133" / 3.38mm) Special Undercut ID Steel Plates
- (1) 062707A (.076" / 1.93mm) Special Undercut ID Steel Plate

DURABILITY AND PERFORMANCE BENEFITS

The patented tooth design furnishes more than double the original tooth contact area which allows the reuse of a 4th clutch shaft that has already been "peened" from the original plates. This unique design also prevents a potential comeback and rework even when you install a NEW 4th shaft!

INSTALLATION INSTRUCTIONS

The steel plates furnished in the above kits are undercut .040" on the inside diameter to clear the redesigned teeth on the friction plate(s). These special steel plates **MUST** be installed. Carefully examine the "peened" area of the 4th clutch shaft. It is suggested that you do not reuse a shaft that is worn more than halfway through the tooth contact area. When reusing a worn shaft, lightly wire buff the tooth contact area. The wire buffing will reduce any ridges that might cause the friction plate(s) to catch or stick on the shaft's splined area during the apply and release. Install the friction and steel plate(s) in the conventional manner. **Note: The bent teeth of the friction plate(s) should be installed facing the channel plate.**

Install the 062758 SINGLE plate kit in the same conventional manner as originally removed. DUAL plate models install in the same conventional manner as originally removed, however, be sure you are installing the correct kit according to the model year and channel plate you are working with. If you have ANY doubts, install the steel and friction plates into the channel plate along the assembled sprocket support, piston and spring retainer. Bolt the support and channel cover together. Air check the 4th piston several times. Check the clutch plate clearance which should average between .040" - .054" on dual plate models.



GM 4T60 & 4T60-E
Fourth Clutch Repair Kit PowerPack®
 Featuring the Patented "BENT TOOTH" Design

MEASURE THE DISTANCE FROM THE STEEL PLATE SURFACE TO THE TOP OF THE GASKET SURFACE. MOST 91-92 CHANNEL PLATES WILL MEASURE BETWEEN .772" - .775". MOST 93-UP CHANNEL PLATES MEASURE BETWEEN .798" - .800". MOST 91-92 CHANNEL PLATES WILL HAVE A CASTING NUMBER OF 8678760 BUT CAN VARY FROM MODEL TO MODEL. THE 93 AND UP CHANNEL PLATES HAVE CASTING NUMBER 8682217 WHICH CARRIES G.M. PART NUMBER 8682617. PLEASE...BE WATCHFUL!

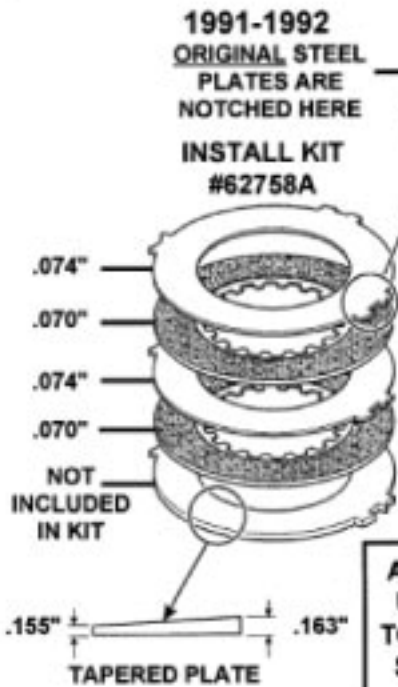
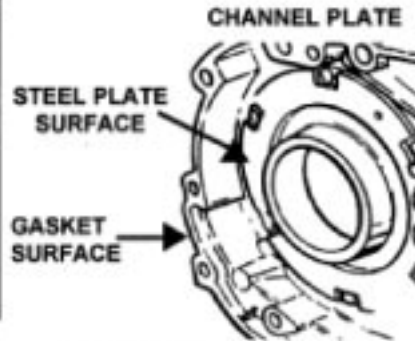

ALTO DOES NOT USE NOTCHES TO IDENTIFY THE STEEL PLATES

