



Chrysler 45RFE, 545RFE Stage 2 Underdrive/Overdrive PowerPack® 99-On

ALTO PART # 128755B

POWERPACK® CONTENTS:

	Picture #
(6) 128741A145 (.057"/1.45mm) Red Eagle® External Spline Friction Plates	(1)
(6) 128740D147 (.058" /1.47mm) Red Eagle® Internal Spline Friction Plates	(2)
(5) 128741A132 (.052"/1.32mm) Red Eagle® External Spline One Sided Friction Plates	(3)
(5) 128740C132 (.052"/1.32mm) Red Eagle® Internal Spline One Sided Friction Plates	(4)
(1) 128761A (.297"/7.54mm) Underdrive Pressure Plate	(5)
(1) 128761A (.297"/7.54mm) Underdrive/Overdrive Pressure Plate	(5)
(1) 128700A230 (.090"/2.30mm) Internal Spline Friction Plate	(4)
(1) 128701-220 (.086"/2.20mm) External Spline Steel Plate	(1)

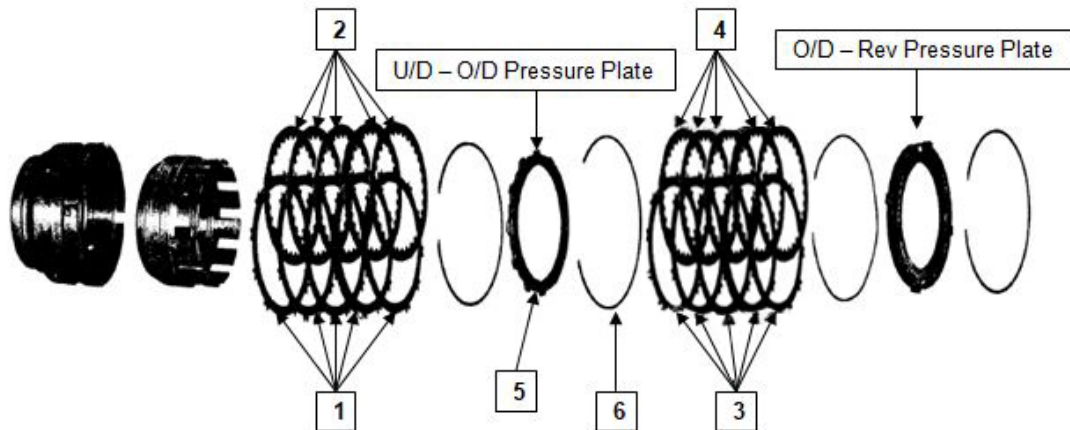

INSTALLATION INSTRUCTIONS

Underdrive: Start the stack-up with the .086" steel plate then a # 1 externally splined friction plate (.052") with the friction lining facing up followed by a # 2 internally splined friction plate (.052") with the friction lining facing up. Continue stacking external and internal friction plates ending with a # 2 internal splined plate. All of the friction plates must have the lining facing up or the clutch will fail. (5 internal and 5 external plates) Install snap ring, install # 5 OE pressure plate with the large step facing down, and install #6 snap ring. Check clutch pack clearance between the pressure plate and the top friction plate in 3 different locations, clearance should be .035" to .065" (.889mm – 1.65 mm).

Overdrive: Start the stack-up with the .090" friction then a # 3 externally splined friction plate (.057") with the friction lining facing up followed by a # 4 internally splined friction plate (.057") with the friction lining facing up. Continue stacking external and internal friction plates ending with a # 4 internal splined plate. All of the friction plates must have the lining facing up or the clutch will fail. (5 internal and 5 external plates) Install the reverse / overdrive pressure plate. Install the top tapered snap ring. Check clutch pack clearance between the pressure plate and the top friction plate in 3 different locations, clearance should be .035" to .065" (.889mm – 1.65 mm). Use # 1 & # 2 (.057") internally or externally splined plates to adjust clutch pack clearance if necessary.

Always pre-soak friction plates in the ATF that you are going to use in the completed unit for at least 30 minutes.



Chrysler 45RFE/545RFE 2nd Clutch PowerPack® Stock, Heavy Duty, Hi-Performance, Race Vehicles

ALTO PART # 128757

Alto # 128757 POWERPACK® CONTENTS:

(3) 128742-203 Red Eagle® Friction Plates

(3) 128703K157 Kolene® Steel Plates

INSTALLATION INSTRUCTIONS

Note: Pre-soak friction plates for at least 15-20 minutes in the manufacturer's recommended ATF.

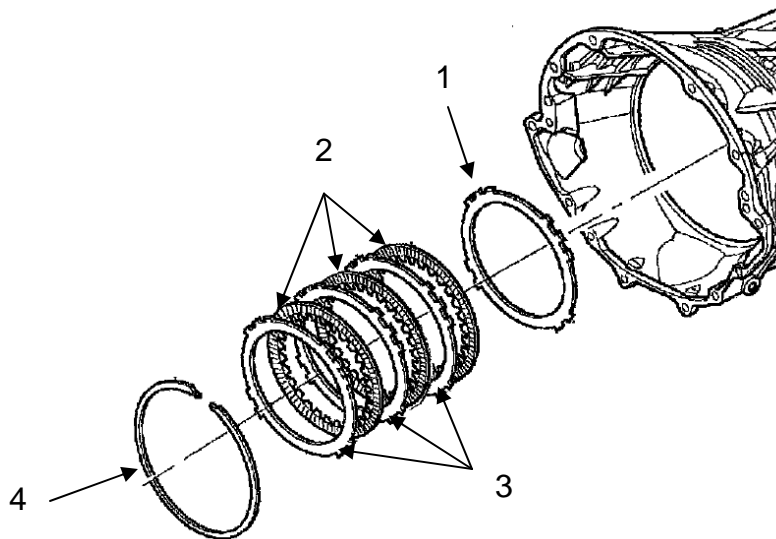

Stack-up is same as OE:

Install the 2C reaction plate (1) into the transmission case.

Install the Alto Red Eagle® frictions (2) and Kolene® steel plates (3), starting with a friction and ending with a steel plate.

Install the Flat 2C snap-ring (4) into the transmission case.

Using air (40 PSI) apply the 2nd clutch several times to seat all of the clutch pack elements

Check clutch pack clearance using a feeler gauge in four places between the reaction plate and the transmission case. Clearance should be 0.455 to 1.335mm (.018" to .053")



Chrysler 45RFE/545RFE 4th Clutch PowerPack®

ALTO PART # 128758

Alto # 128758 POWERPACK® CONTENTS:

- (4) 128744-203 Red Eagle® Friction Plates
- (4) 128705K157 Kolene® Steel Plates
- (1) 128765-500 Pressure Plate

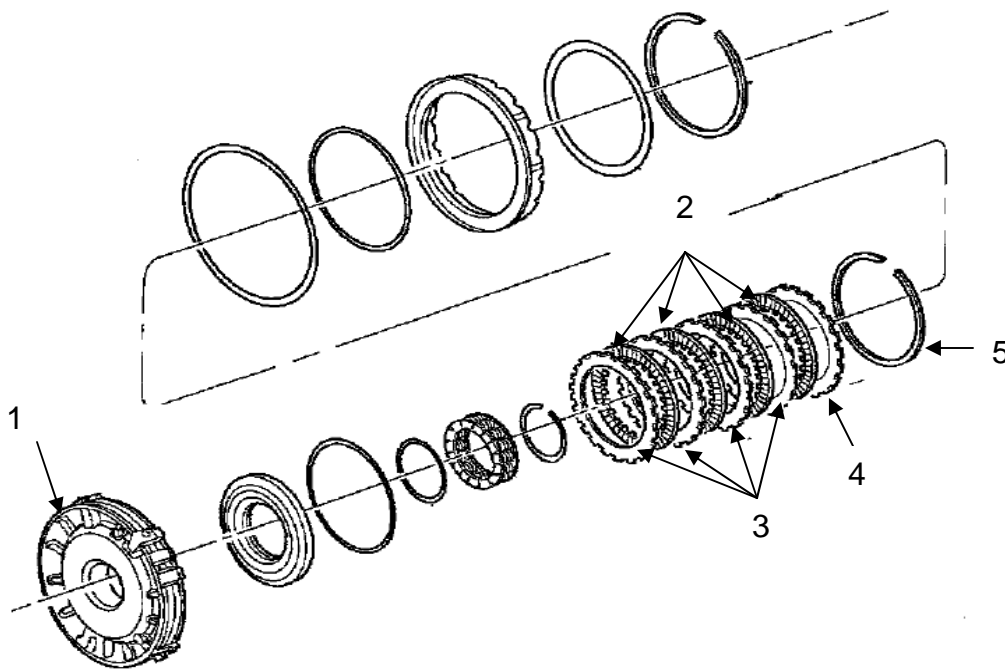

INSTALLATION INSTRUCTIONS

Stack-up is same as OE:

Install the Alto Red Eagle® frictions (2) and Kolene® steel plates (3), starting with a steel plate and ending with a friction plate into the 4C housing (1)

Install the top pressure plate (4)

Install the Flat 4C selective snap-ring (5) into the 4C housing

Check clutch pack clearance using a feeler gauge in four places between the Pressure plate and the snap ring. Clearance should be 0.770 to 1.390mm (.030" to .055")

Adjustment made by selective snap rings available from dealer.