



Chrysler A518/618/TF8/727 Front Clutch PowerPack®

ALTO PART # 028755

Alto # 028755 POWERPACK® CONTENTS:

- (7) 028742A155 (.061" / 1.55mm) Red Eagle® Friction Plates
- (6) 028701K (.068" / 1.72mm) Kolene® Steel Plates
- (2) 028701K216 (.085" / 2.15mm) Kolene® Steel Plates
- (1) 028761X (.170/4.32mm) Pressure Plate

INSTALLATION INSTRUCTIONS

The stack-up of the front clutch is the same as OE with the exception of adding additional plates. Use the combination of .068" steel plates and .085" steel plates to achieve the correct clutch pack clearance. You will be capable of stacking 5/6 frictions and 5/6 steels in the A518, and 6/7 friction and 6/7 steels in the A618, and 5/6 frictions or 6/7 steels into the TF8/727 depending on drum. If you use the pressure plate supplied in this kit, you can change to the higher numbers of plates, if you use the OE pressure plate you can install the lower number of plates. (Thanks to Hitech Products).

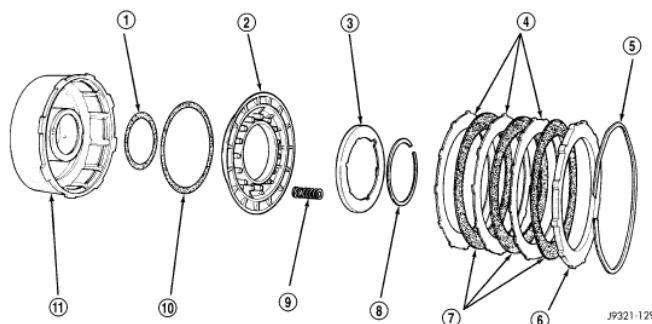
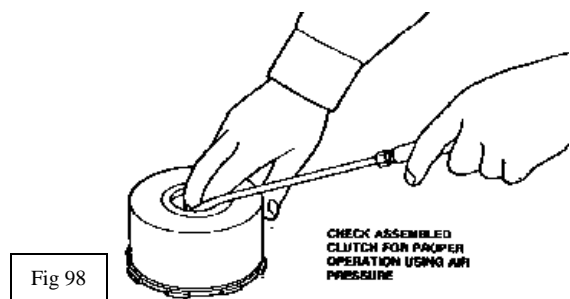

Fig. 95 Front Clutch Components

- | | |
|-----------------------------------|-------------------------------|
| 1 - INNER PISTON SEAL | 7 - CLUTCH DISCS |
| 2 - CLUTCH PISTON | 8 - RETAINER SNAP-RING |
| 3 - CLUTCH PISTON SPRING RETAINER | 9 - CLUTCH PISTON SPRINGS (9) |
| 4 - CLUTCH PLATES | 10 - OUTER PISTON SEAL |
| 5 - CLUTCH PACK SNAP-RING (WAVED) | 11 - FRONT CLUTCH RETAINER |
| 6 - REACTION PLATE | |

After assembly of drum, apply the clutch pack several times with air to seat all components (Fig. 98). Check clutch pack clearance using a feeler gauge. Insert feeler gauge between wave snap ring and pressure plate. Clearance should be .070" to .129" (1.78mm to 3.28mm). If clearance is incorrect, clutch plates, snap ring, or pressure plate may have to be changed. (Fig 99).



CHECK ASSEMBLED CLUTCH FOR PROPER OPERATION USING AIR PRESSURE

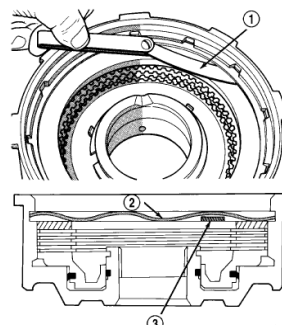

Fig. 99 Typical Method Of Measuring Front Clutch Pack Clearance

- 1 - FEELER GAUGE
- 2 - WAVED SNAP-RING
- 3 - FEELER GAUGE

